

**You automate high-performance machines and production lines
u-remote generates maximum efficiency in your projects
Let's connect.**

Remote I/O

**Integrated
Safety**



Weidmüller 



Machine automation with clear added value

u-remote combines powerful technologies with short project durations

You want to perform your machine development operations – from the automation concept to the stable machine operation – in such a way that they are fast, high-performance, smooth and deliver identifiable added value for your customers. The decisive factors for your project's success are consistently efficient processes and unique functions.

With u-remote you're laying the foundation for this. By implementing powerful and easy-to-use signal connection components, you will reap early on the advantages for installation work, machine commissioning and subsequent service applications at your customers' premises.

From planning to operation, u-remote allows you to speed up all processes and opens up new possibilities for intelligent system architecture. The result available to you is an innovative I/O system which is the perfect response to growing complexity in machine and factory automation thanks to its powerful flexibility and simple handling.

Our formula: "More Performance. Simplified. u-remote."



Cost-saving and flexible system configuration

Easy to install



Faster commissioning

Improved operational availability



Machine automation with clear added value

u-remote combines powerful technologies with short project durations



No space for efficiency losses

Design your cabinets to be a size smaller – yet still offer full flexibility and simplified processes. With its compact technology and outstanding performance, u-remote offers you a solution that saves money and takes up minimal space.



Simply faster to connect up

For an accurately installed system in the fastest time possible, u-remote relies on seamlessly pluggable handling and a clear overview. So each handle is properly positioned the first time round.



Simple start to series production in an extremely short space of time

A few steps to productive operation – to achieve this, u-remote combines sophisticated diagnostics and accelerated work processes. So your machine starts up without any errors within a very short time.



Notably improved productivity

Ensure that your machines and production lines have significantly shorter downtimes. u-remote combines innovative functions and a modular design to create a key advantage for maintenance and service work.

No space for efficiency losses

u-remote enables the most miniature of system solutions that deliver maximum performance

Its savings potential is the only thing that is large about u-remote. With the most innovative I/O system on the market, you can plan your cabinets to be a whole size smaller. Thereby, this high-performance concept not only makes your automation solutions more affordable, but also more efficient in every respect. By coming up with new ideas and technologies and delivering the highest connection density on the market, we simplify the planning process for you and provide you with plenty of reserves for the future.

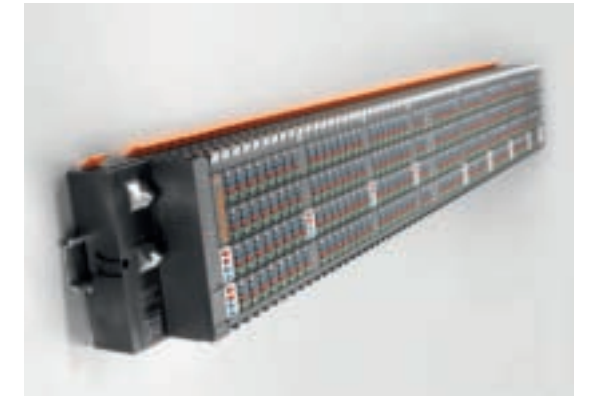

More connections on a narrower width

Up to 32 connections on just one module – that's got to be a world record! Connecting eight individually pluggable 4-conductor sensors in the tightest of spaces is child's play. And you even reduce the number of I/O modules required for signal connection.

One feed-in is enough

Design your system to be more compact: The high-performance 4 A supply path allows you to operate 64 I/O modules with just one power supply – saving on power-feed modules, thus making your planning process simple and quick.



Unique separation

It's a feature you'll only find with u-remote: a separate I/O supply via two highly robust 10 A current paths. Due to the high performance you will save power-feed modules as well as space. At the same time you reduce the planning effort, as you no longer have to perform any consumption calculations.



Configured to be thinner

With a module width of just 11.5 mm, u-remote is thinner than any other I/O system. And because intelligent miniaturisation even creates space for more innovations, it now comes with up to 32 connections per module. So you have space left over for flexibility and solutions that save money.

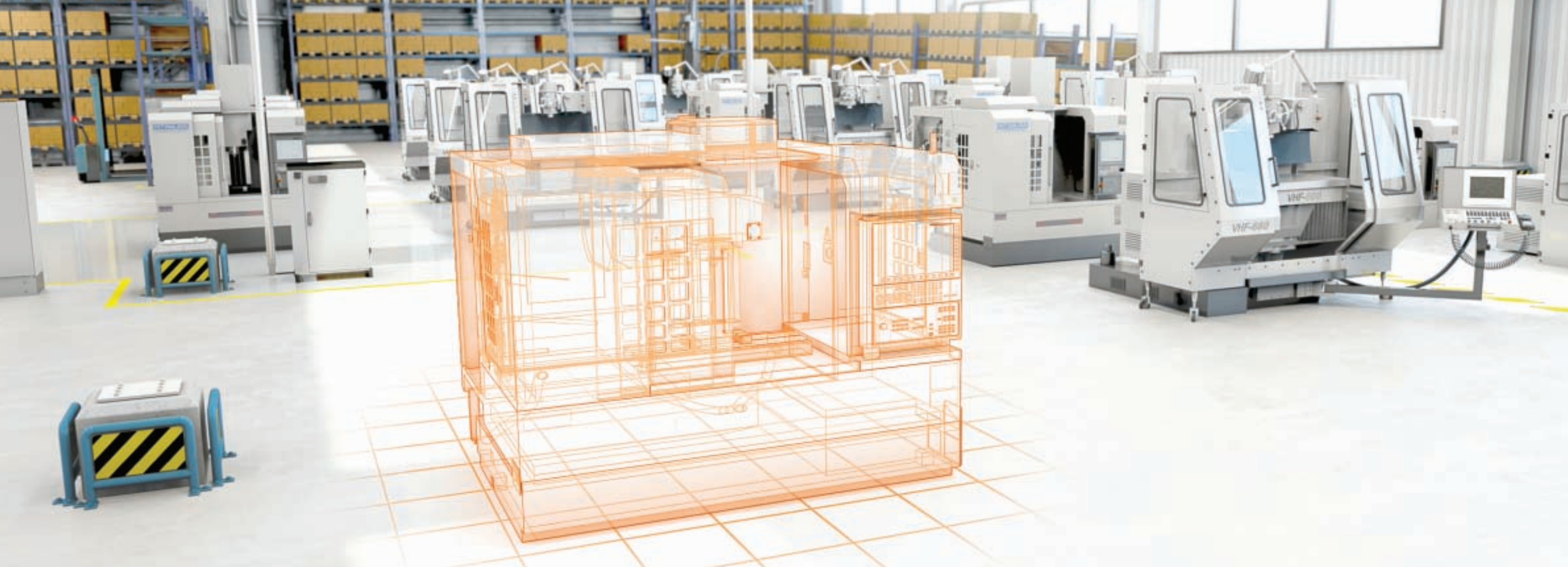

Smarter automation specified in a simpler way

u-remote simplifies your planning activities and offers unique functions

Implement your customers' requirements in a perceptibly simpler and quicker manner. Therefore, u-remote changes the way you work. Your system configuration is simplified. Your automation design is made more flexible. And your systems become more powerful.

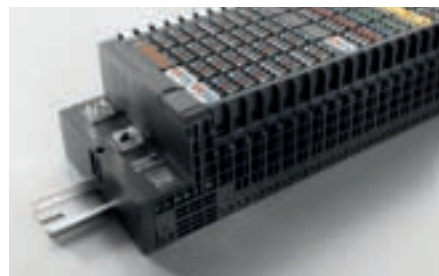

Fewer calculation constraints give you more freedom in design

Minimal yet structured by function – that's what your new I/O system looks like. With far fewer calculations to do, you can have more freedom and flexibility in your planning activities than ever before. After all, only with u-remote is the supply for the inputs and outputs separated by two distinct 10 A current paths. So you can flexibly distribute the I/O modules according to the logical structure of your sensor and actuator architecture while saving power-feed modules at the same time.



Prepare for the future today

Maximum performance in real time: short response times, addressable at speed and a precise mapping of processes in your machine. The high-speed system bus offers you maximum power reserves, even for the requirements of future applications.



Solutions for a wide range of applications

Effortlessly coordinate your solution to your customers' specific requirements. u-remote is independent of any fieldbuses and can easily be adapted and migrated to a multitude of systems.

What's more, u-remote boasts an extremely robust design, is temperature-stable and, of course, also meets the common standards and requirements.



Simpler planning

Speed up your selection process: with a wide diversity of variants due to parameterisation, not a multitude of modules. For you, this translates into only one part number per module, a simplified module selection process and fewer spare parts stored on stock.

Simply faster to connect up

u-remote minimises cabling errors and is intuitive to use and handle

Handle your projects with maximum performance. u-remote makes your installation process more reliable and faster. The seamlessly pluggable system means that you can rely on your intuition and trust that there will be no errors. Simple handling and a unique function detection are now set to be noticeable factors in the success of your project.



Simply plug and go

The fastest way to productive operation: Connect sensors and actuators with pre-assembled cables. You save time, improve usage and handling and minimise the error rate. It's ideal, especially for decentralised sub-assemblies and tight spaces.



Zero errors with higher performance

A single-row connection strip, a clear structure – the assignment to the circuit diagrams is clear. u-remote allows you to avoid cabling errors even when working in a fast-paced environment. Unique: the innovative HD modules allow for connection of eight individually pluggable 4-conductor sensors.



Clear colours, clear functions

Easy working thanks to an innovative colour concept. You can identify all key functions at a glance and the coloured pushers guarantee intuitively correct working.



Direct insertion – direct savings

All you have to do is inserting the conductor into the clamping unit until it stops – job done. Our "PUSH IN" technology not only makes cabling twice as fast for you, but also offers you uncompromised connection safety. And, of course, you don't even need any tools.



Systematic flexibility

For every type of sensor and actuator, four-pin plug-in connectors give you free choice on conductor technology. So you can use the installation option that suits your project with either 2, 3, "3 plus FE" or 4-conductor technology.

Simple start to series production within a very short space of time u-remote scores top marks with sophisticated diagnostics

u-remote allows your machines to start up noticeably faster. Clever diagnostic functions make long troubleshooting processes a thing of the past. Thanks to uniquely simple system handling, you can correct signal wiring in a flash.



Ready for operation earlier on thanks to integrated diagnostics

u-remote enables start-up in sections even before machinery is commissioned. Using the high-performance web server, you can parameterise and simulate the functionality of inputs and outputs prior to connect a control. You can easily conduct plain text error analyses using a standard browser – whether you're working on-site or remotely.



Consistent minimisation of errors

u-remote's modular design makes for shorter machine start-up. The intuitive handling, seamless pluggability and single-row connection strip make your work easy and reduce cabling errors.

Clearly identified

An overview makes everything easier. With the extensive range of marking options down to the individual connection point, you can identify functions in a unique fashion and reduce the error rate.



Simply faster to work on

As all the components are handled without tools, your work processes are shortened. For example, you can expand your station in a few quick movements or very easily correct the order of the modules.

Notably improved production performance

u-remote significantly increases your machines' operating availability

Score top marks from your customers with maximum machine availability. u-remote is the most user-friendly I/O concept on the market that you can use to combine high-performance automation with optimum system handling. This gives your machines a convincing range of functions, decisively minimising the time and effort involved in service and maintenance.



Improve system availability

The separate I/O current paths enable service activities to be performed while the sensor system is active, since inputs and outputs are switched off independently of one another. So your machine is up and running again in a flash.

Minimise machine downtimes

The machine may be at a standstill, but communication is still ongoing: u-remote is completely hot-swap-capable. Replace the electronics without the need to switch off the I/O system. A safe solution to keep machine downtimes as short as possible.



Fast and targeted reactions on machine standstill

Shorten production downtimes with unique plain text diagnostics via the integrated web server. In case of an emergency stop, you can identify errors faster and rectify them in a targeted fashion.



Immediately identify errors

Error diagnosis has never been so easy: You can localise errors instantly with an LED directly on the channel and status indicators on every module. An indispensable benefit for secure commissioning and rapid system maintenance.

Smart support

Thanks to the printed QR code, you can access installation instructions and technical data online. The direct link takes you to all the key information about the scanned component.

Fully designed with safety in mind

u-remote offers integrated safety for both people and machines

Communicative systems such as u-remote form part of the future in factory automation. For safety, this means that even after triggering an emergency stop, it is still possible to call up the system's current status – regardless of how big the safety application is.

With u-remote, a reliable machine shutdown is guaranteed while keeping the sensors active. And after maintenance, you can restart system operation immediately. u-remote enables this with two needs-based safety technologies.

Integrated safety without a safety control

Implement safety solutions by practical and effortless connection to the control. Simply position your safe power-feed module directly upstream of the corresponding standard output modules – and that's the configuration of your safety technology complete. And that's without the need for costly safe PLCs featuring appropriate outputs or the additional use of safety relays.

By safe shutdown of the output current path you switch off actuators selectively and at the same time, keep the sensors fully active. You can therefore send the machine status to the control at any time, and it quickly takes over the restart operation once the problem has been rectified.

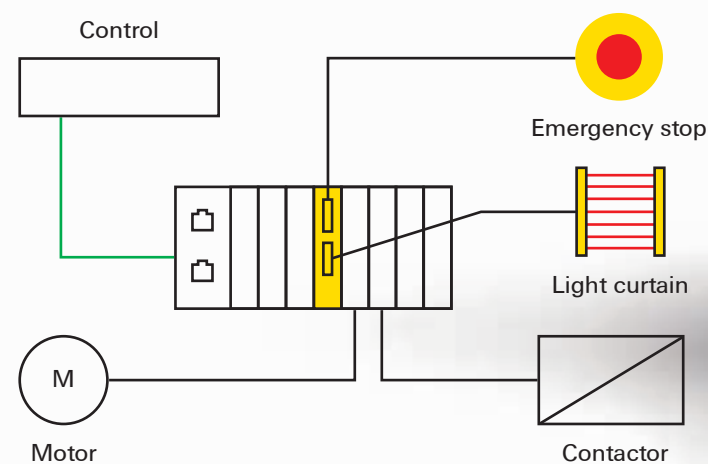

Safety over
EtherCAT®

Your special advantages

Integrated discrete solutions without expensive safety PLC

- Unique on the market: u-remote safe power-feed modules
- Cascadability of safety circuits
- Safe switch-off of standard output modules

Integrated solutions for distributed safety applications

- Smallest possible safety I/O solution – highest functional density available
- Safe 4DI-4DO modules combine various safety functions on only 11.5 mm width
- Easy system configuration due to less variants of safe I/O modules

Safely control complex systems using modern fieldbus technology

Think and work in a networked fashion. Use u-remote to connect distributed safety equipment to form a fully cooperating safety system, which is monitored using a centralised safety control. The safe u-remote input and output modules can be ideally integrated in decentralised architectures to selectively switch off parts of the production as required.

You can use PROFIsafe modules for the PROFIBUS and PROFINET fieldbuses. Fail Safe over EtherCAT (FSoE) is designed for EtherCAT.

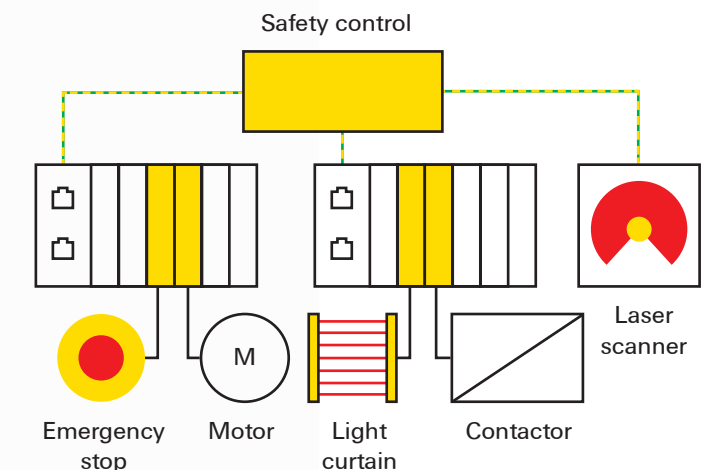

Configure and calculate your customised I/O system the easy way

The u-remote configurator shortens your planning times

A superior tool for your planning process: Assemble your complete I/O system the quick and easy way with the u-remote configurator.

From the DIN rail, over the coupler, to the modules, the configurator offers you the best practice variation or alternative system components upon request – always perfectly coordinated to your application. Save yourself time and effort:

- Complete system configuration via one interface
- Automatic testing of all the planned stations
- Display and rectification of configuration errors

Save yourself work

Naturally included in our professional planning tool: For a better overview, you can display the dimensions, product information and comments on individual modules and module groups. Also, the configurator automatically creates a detailed list of part numbers, planning data and standard configurations for you.

With just one click of the mouse, you can request a non-binding quotation for your customised u-remote configuration.

Compose I/O systems the simple and safe way: Test our u-remote configurator now!

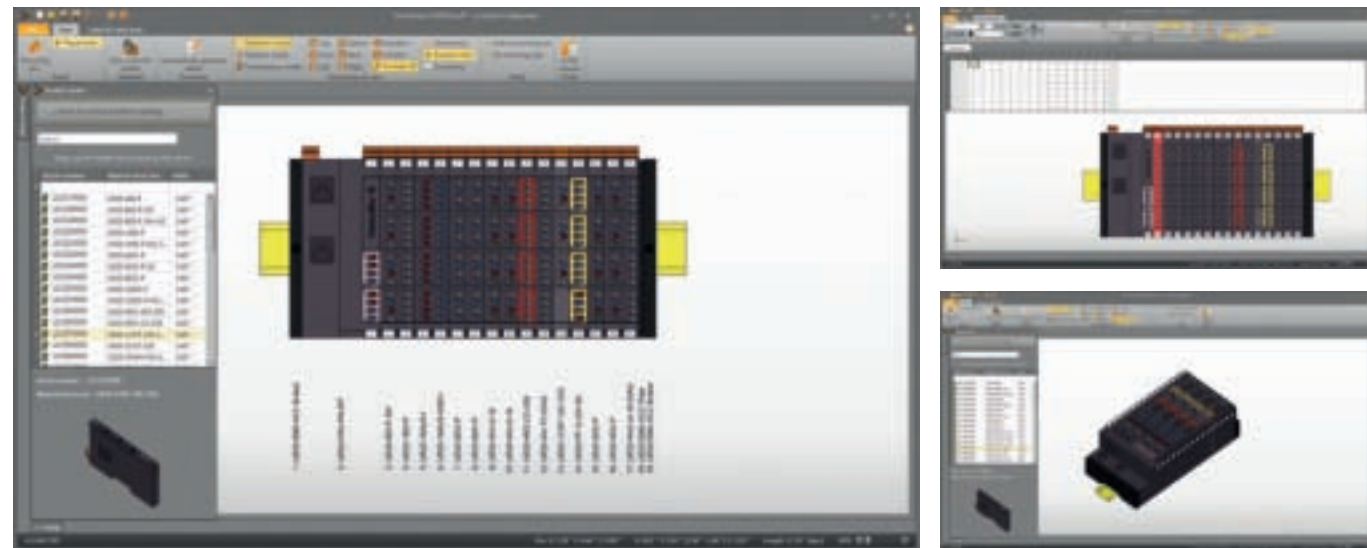

Put through its paces and incorporated in your system

Weidmüller provides you with active support in your projects

Realise your full potential with the help of our experts

u-remote is extremely easy to implement – both as part of completely new projects and during re-designs and system optimisations to existing machine concepts. But Weidmüller won't leave you alone in this regard. Because we want to make your work on your projects as simple as possible.

You benefit from our wide range of advisory and support services. Our experienced application specialists will be more than happy to develop additional optimisation opportunities in complex system architectures together with you.

Experience the convincing concept of u-remote with your own eyes

Ask for a personal product sample or a fully functional u-remote test station that you can use to put our system through its paces today. You'll be inspired by u-remote's simple handling, its high system performance and its efficient and flexible potential uses.

www.u-remote.net

The best connections from a single source

u-remote supplements our range of products in any application

Marking

Everything clearly identified: Mark your u-remote station with our perfectly harmonised range of products for professional and standardised industrial marking.

- MultiCard program with more than 200 marker variants
- M-Print® PRO software for effortless designing, labelling and ordering
- The PrintJet ADVANCED printer delivers a wipe- and scratch-proof printing result – even in colour

Communicating

Efficiently connect your automation solution with the process management level also in IP 67 – with Industrial Ethernet-Solutions of any kind of protection level:

- IE Value Line: Unmanaged and managed switches, Fast Ethernet and Gigabit Ethernet ports, multitude of helpful management functions
- IE Premium Line: Extended management and security functions, Fast Ethernet and Power-over-Ethernet ports, ring redundancy technology for increased availability

Isolating and switching

Our relay modules, solid-state relays and signal converters cut an impressive figure in the 6 mm modular terminal format – for consistently perfect-fit signal connection solutions.

- TERMSERIES relay modules: Fixed voltage inputs or multi-voltage input, distinct LED status indicator
- MICROOPTO solid-state relays: Short-circuit-proof output, long-lasting thanks to MTBF time
- ACT20M signal converters: Processing of a spate of analogue signals in an extremely tight space, easy configuration and with a high galvanic isolation

Supply

Our switched-mode power supply units and modules for uninterruptible power supply (DC-USP) ensure that you are permanently supplied.

- Especially economical PROeco power packs: Low depth of just 100 mm, up to 93 % efficiency
- Extremely powerful PROmax power packs: Input voltage range of up to 277 V AC, surge protection category III and SEMI F47
- DC-USP modules: Bridging of power failures lasting up to 30 hours, deep discharge protection and temperature-compensated battery charging, extensive status monitoring

Cabling

We meet your connection requirements from the cabinet to the field – with integrated networking solutions for power, signals and data. You will benefit from a high degree of standardisation with maximum flexibility and scalability.

- Industrial Ethernet cord sets and plug-in connectors
- Sensor-actuator cables and plug-in connectors
- Assembled cables
- Heavy-duty connectors



Weidmüller – Your Partner in Industrial Connectivity

Let's connect.

As experienced experts we support our customers and partners around the world with products, solutions and services in the industrial environment of power, signal and data. We are at home in their industries and markets and know the technological challenges of tomorrow. We are therefore continuously developing innovative, sustainable and useful solutions for their individual needs. Together we set standards in Industrial Connectivity.



www.u-remote.net

Visit u-remote online and see for yourself the unbeatable benefits of the remote I/O system from Weidmüller. Includes a descriptive demonstration video, detailed product overview and information that you can download. Let's connect.

Weidmüller Interface GmbH & Co. KG
Klingenbergstraße 16
32758 Detmold, Germany
T +49 5231 14-0
F +49 5231 14-292083
info@weidmueller.com
www.weidmueller.com

You can find your local Weidmüller contact on the Internet at:
www.weidmueller.com/countries

Made in Germany



4 050118 394801

Order number: 2009170000/04/2015/SMKW